

I B. Tech II Semester Regular Examinations, June/July-2024**DATA STRUCTURES**

(Common to CSE, IT& CSE-Allied)

Time: 3 hours

Max. Marks: 70

- Note: 1. Question paper consists of two parts (**Part-A** and **Part-B**)
2. All the questions in **Part-A** is Compulsory
3. Answer **ONE** Question from each Unit in **Part-B***

PART -A (20 Marks)

1. a) Describe the types of Data Structures. [2M]
- b) Classify sorting algorithms. [2M]
- c) What are the main differences between the Linked List and Linear Array? [2M]
- d) How many pointers are necessary to implement a simple Linked List? [2M]
- e) What do you mean by Stack? [2M]
- f) Why and when should use stack or queue data structures instead of arrays? [2M]
- g) What are the benefits of circular queue? [2M]
- h) Write the function to display elements on Queue with two ends. [2M]
- i) What are the applications of binary trees? [2M]
- j) Define Hash Function. [2M]

PART - B (50 MARKS)**UNIT-I**

2. a) Explain time and space complexity analysis for linear data structures with suitable example. [5M]
- b) Explain about bubble sort technique with example. [5M]

(OR)

3. a) Explain about Linear Search technique with example. [5M]
- b) What is an abstract data type (ADT)? What are the basic operations typically associated with ADTs? [5M]

UNIT-II

4. a) Write an algorithm to insert new node at the beginning, at middle position and at the end of a Singly Linked List. [5M]
- b) What are the advantages and disadvantages of Linked list over Arrays. Write a simple program to store student details. [5M]

(OR)

5. a) Write the pseudo code for insertion, deletion and search operations on double linked list. [5M]
- b) What is linked list? Explain how sparse matrices can be represented using linked lists? [5M]

UNIT-III

6. a) Write an algorithm to implement backtracking. Give some applications. [5M]
- b) Explain how Infix to postfix Transformation can be done using stacks. Give suitable example. [5M]

(OR)

7. a) Write an algorithm to print reversing list using stack. [5M]
- b) Explain how an arithmetic expression can be evaluated using stack. Give suitable example. [5M]

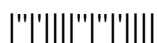

UNIT-IV

8. a) Write an algorithm to implement queue using arrays. [5M]
b) Describe how queues are utilized in breadth-first search algorithm. [5M]

(OR)

9. a) Define double-ended queues and outline their operations, including insertion and deletion operations at both ends. [5M]
b) Discuss the applications of dequeues with suitable example. [5M]

UNIT-V

10. a) Write about the concepts of open addressing and write the algorithm to implement it. [5M]
b) Explain the insertion and deletion operation on the Binary search tree? Write the algorithm for the operations? [5M]

(OR)

11. a) What is meant by hash table? Explain its implementation. [5M]
b) Explain application of hashing in caching with examples. [5M]

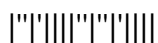

I B. Tech II Semester Regular Examinations, June/July-2024**DATA STRUCTURES**

(Common to CSE, IT& CSE-Allied)

Time: 3 hours

Max. Marks: 70

*Note: 1. Question paper consists of two parts (Part-A and Part-B)**2. All the questions in Part-A is Compulsory**3. Answer ONE Question from each Unit in Part-B***PART -A (20 Marks)**

1. a) What is a Linear Data Structure? Name a few examples. [2M]
- b) Which sort algorithm works best on mostly sorted data? [2M]
- c) How can you represent a linked list node? [2M]
- d) Write some applications which use Linked Lists. [2M]
- e) Write the application of stack in search operation. [2M]
- f) Explain why stack is recursive data structure. [2M]
- g) Write different types of Queues. [2M]
- h) List the applications of circular queue. [2M]
- i) What are the properties of binary search tree? [2M]
- j) Define Hash table. [2M]

PART - B (50 MARKS)**UNIT-I**

2. a) How do time and space complexity analysis help in understanding and comparing different algorithms or data structures? [5M]
- b) Explain about Insertion sort technique with example [5M]

(OR)

3. a) Explain about Binary Search technique with example. [5M]
- b) Write a program to print elements of given array in reverse order and analyze its time and space complexities. [5M]

UNIT-II

4. a) Describe the structure of Double linked list. Devise the operations on Double linked list. Give the suitable examples. [5M]
- b) Explain the representation of polynomial expressions using linked list. [5M]

(OR)

5. a) Describe the structure of Circular linked list. Devise the operations on Circular linked list. Give the suitable examples. [5M]
- b) Explain applications of linked lists with suitable example. [5M]

UNIT-III

6. a) Write an algorithm to implement stacks using arrays. [5M]
- b) Convert the following Infix expression to postfix and prefix expression. [5M]
(a + b / c) * d / (e - f) + g

(OR)

7. a) Briefly explain the properties and operations of stack. [5M]
- b) Explain application of Stack in recursive functions with example. [5M]

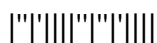

UNIT-IV

8. a) Write an algorithm to implement queue using linked list. [5M]
b) Discuss the applications of queue in scheduling algorithm. [5M]

(OR)

9. a) Describe the insertion and deletion operations of queues at both ends. [5M]
b) Discuss the applications of dequeues with suitable example. [5M]

UNIT-V

10. a) Write a recursive algorithm for in-order, pre-order, post-order tree traversals. [5M]
b) What is binary search tree? Construct the Binary search tree for 30, 27, 12, 45, 52, 2, 37, 18, 49, 12, 30 [5M]

(OR)

11. a) What is collision in hash table? Explain how collision can be resolved using separate chaining. [5M]
b) Discuss the applications of hashing in unique identifier generation. [5M]

2 of 2

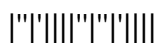

I B. Tech II Semester Regular Examinations, June/July-2024**DATA STRUCTURES**

(Common to CSE, IT& CSE-Allied)

Time: 3 hours

Max. Marks: 70

*Note: 1. Question paper consists of two parts (Part-A and Part-B)
2. All the questions in Part-A is Compulsory
3. Answer ONE Question from each Unit in Part-B*

PART -A (20 Marks)

1. a) What is the significance of abstract data type (ADT) [2M]
- b) Write a note on implicit and explicit sorting techniques. [2M]
- c) Illustrate the display operation of circular linked lists. [2M]
- d) Write various types of lists. [2M]
- e) What are the principles of Last-In-First-Out (LIFO). [2M]
- f) Define the term backtracking. [2M]
- g) List the applications of queues. [2M]
- h) What is dequeue? [2M]
- i) What is collision? [2M]
- j) What is a binary search tree traversal? [2M]

PART - B (50 MARKS)**UNIT-I**

2. a) What is binary search? Write an algorithm for binary search and trace with an example. [5M]
- b) Write and explain the algorithm for selection sort with example. [5M]

(OR)

3. a) What is the linear search? Explain the time and space complexity analysis of linear search algorithm. [5M]
- b) Write an algorithm for insertion sort? Trace with an example. [5M]

UNIT-II

4. a) Describe the concept of a circular linked list and its implementation. Discuss the advantages of circular linked lists. [5M]
- b) Explain the differences between arrays and linked lists in terms of their implementation and performance. [5M]

(OR)

5. Explain the representation of single linked list and its implementation. Write the pseudo code for insertion, deletion and traversal operations on single linked list. [10M]

UNIT-III

6. a) Explain the working principle and operations of stacks with program. [5M]
- b) Describe the process of implementing stack operations such as push and pop using Linked list. [5M]

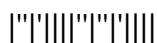

(OR)

7. a) Explain the implementation of stacks using arrays. Write the algorithm for push and pop operations. [5M]
b) How stacks are used to evaluate arithmetic expressions. Explain with example. [5M]

UNIT-IV

8. a) Compare and contrast the implementation of queues using arrays and linked lists. [5M]
b) Describe the operations on deques, including insertion, deletion, and traversal. [5M]

(OR)

9. a) Write the algorithm for enqueue and dequeue operations using linked lists. [5M]
b) Discuss the role of queues in scheduling algorithms for task management. Explain. [5M]

UNIT-V

10. What is binary search tree (BST)? Describe the process of inserting a node into a binary search tree. Explain the algorithm for BST insertion, analyze its time complexity and give the suitable examples. [10M]

(OR)

11. a) What is hash function? Explain the different hash functions with examples. [5M]
b) Explain the structure of hash table and its operations. [5M]

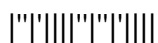

I B. Tech II Semester Regular Examinations, June/July-2024**DATA STRUCTURES**

(Common to CSE, IT& CSE-Allied)

Time: 3 hours

Max. Marks: 70

*Note: 1. Question paper consists of two parts (Part-A and Part-B)
2. All the questions in Part-A is Compulsory
3. Answer ONE Question from each Unit in Part-B*

PART –A (20 Marks)

1. a) Write the pseudo code for linear searching. [2M]
- b) What is the advantage of insertion sort? [2M]
- c) Define a linked list. [2M]
- d) How does a circular linked list differ from a linear linked list? [2M]
- e) List the applications of stacks. [2M]
- f) What is the importance of Top of Stack? [2M]
- g) Write a note scheduling with queues. [2M]
- h) Specify the significance of queues in memory management. [2M]
- i) How can you minimize collisions in hash tables? [2M]
- j) Name different types of tree traversals. [2M]

PART – B (50 MARKS)**UNIT-I**

2. a) What is the difference between linear sort and binary sort? Analyze the time complexity analysis. [5M]
- b) What is linear data structure? List various types and explain the algorithm for implementation of any one. [5M]

(OR)

3. a) Explain the insertion sort and its implementation. [5M]
- b) Write the recursive and iterative algorithm for binary search and explain its time complexity. [5M]

UNIT-II

4. Explain the representation and operations of singly linked lists. Explain how nodes are linked in a singly linked list and describe operations such as insertion, deletion, and traversal with suitable examples. Write the pseudo code for operations. [10M]

(OR)

5. a) Differentiate the insertion of new node in double and circular linked lists with pseudo code. [5M]
- b) Describe the concept of a doubly linked list and its implementation. Discuss the advantages of doubly linked lists over singly linked lists. [5M]

UNIT-III

6. a) Write the algorithm for push and pop operations of stacks using linked lists. [5M]
- b) Discuss the role of stacks in backtracking algorithms. Explain how stacks facilitate backtracking. [5M]

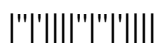

(OR)

7. a) How stacks are used for infix to postfix conversion? Explain with example. [5M]
b) Describe the process of implementing stack operations push and pop using arrays. [5M]

UNIT-IV

8. a) Discuss the properties and operations of queues in detail, emphasizing the First-In-First-Out (FIFO) principle. [5M]
b) Explain the applications of deques in data structure algorithms and problem-solving. Provide some examples. [5M]

(OR)

9. a) Explain the implementation of queues using arrays. Write the algorithm for enqueue and dequeue operations. [5M]
b) Explain the applications of queues in breadth-first search (BFS) algorithms for graph traversal. [5M]

UNIT-V

10. a) Explain the basic implementation of hash tables and the operations supported by hash tables, such as insertion, deletion, and search. [5M]
b) What is binary search tree? Explain its operations with example. [5M]

(OR)

11. What is collision? Explain with example. Explain the different collision resolution techniques with examples. [10M]

2 of 2

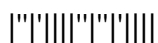

I B. Tech II Semester Regular Examinations, June/July-2024

ELECTRICAL CIRCUIT ANALYSIS-I

(Electrical and Electronics Engineering)

Time: 3 hours

Max. Marks: 70

Note: 1. Question paper consists of two parts (**Part-A** and **Part-B**)

2. All the questions in **Part-A** is Compulsory

3. Answer **ONE** Question from each Unit in **Part-B**

PART – A (20 Marks)

1. a) What is the relationship between voltage and current in an inductor? Write equation. [2M]
- b) What is the relationship between the current in resistors that are connected in parallel? [2M]
- c) Relate flux, reluctance and MMF? [2M]
- d) What are the minimum and maximum values of coefficient of coupling? [2M]
- e) What is the relationship between maximum and RMS value in a sinusoidal supply? [2M]
- f) What is the phasor relationship between voltage and current in a series RC circuit? [2M]
- g) What is the range of quality factor? [2M]
- h) What is the shape of impedance locus diagram of series RL circuit? [2M]
- i) What are the properties of a linear circuit? [2M]
- j) How to find thevenin's voltage? [2M]

PART – B (50 MARKS)**UNIT-I**

2. a) By considering a series connection of three resistors with a DC voltage source, determine the relationship between voltages across different resistors and also determine the relationship between currents in different resistors. [5M]
- b) In the circuit below, determine range of values of the currents I_1 & I_2 and Voltages V_1 and V_2 [5M]

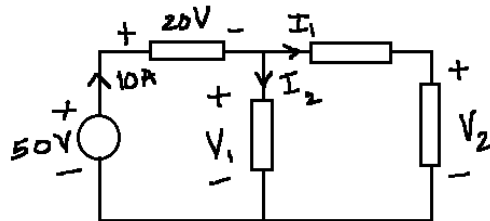

(OR)

3. a) What are the various network reduction techniques? Discuss briefly. [5M]
- b) In the circuit below, determine all the node voltages. [5M]

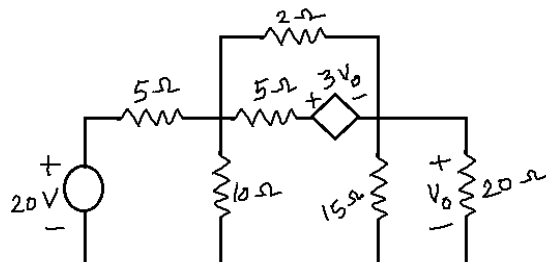

UNIT-II

4. For the network below, determine I_1, I_2, I_3 and I_4 in the circuit below. [10M]

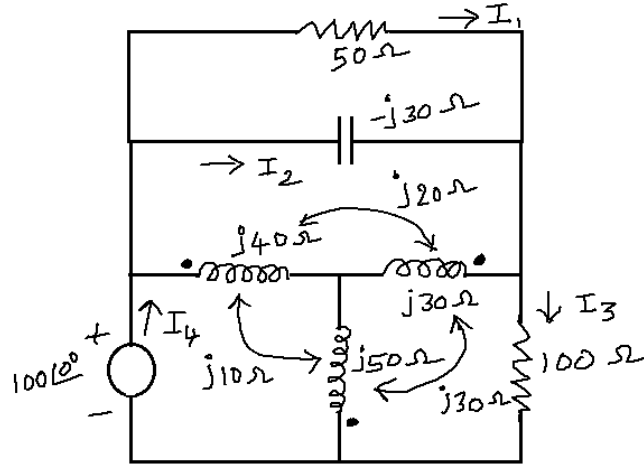

(OR)

5. In the magnetic circuit below, all the dimensions are in cm. Given the relative permeability of magnetic core is 3000 and the cross sectional area of the core is 25 cm^2 . Neglect fringing. Determine the magnetic flux in the coil and also determine the magnetic flux in every part of magnetic core and the air gap. [10M]

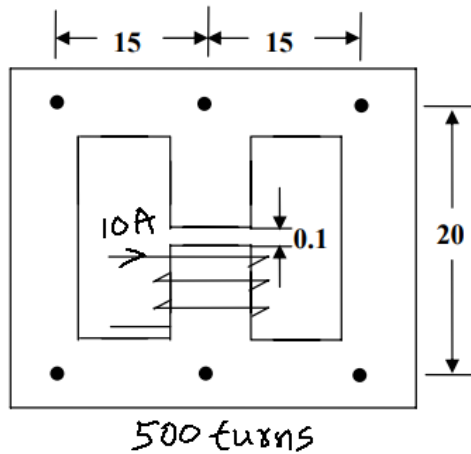

UNIT-III

6. For the periodic waveform below, determine Average value, RMS value and form factor. [10M]

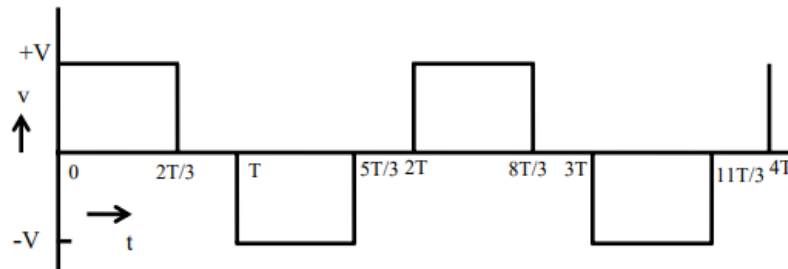

(OR)

7. In a series-parallel circuit shown below, the two parallel branches A and B, are in series with the branch C. The voltage across the branch, C is $(150+j0)$ V. Find the currents and voltages in all the impedances. Find also the input voltage. Draw the phasor diagram. [10M]

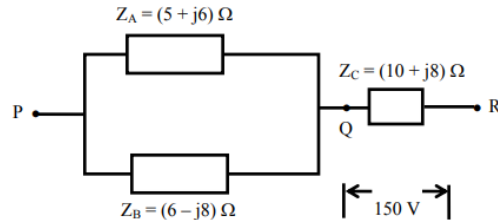

UNIT-IV

8. Draw the impedance and admittance locus diagrams of series RL circuit and derive the relationship between the frequency and impedance & admittance in the circuit. [10M]

(OR)

9. Design a parallel resonant RLC circuit with $\omega_0 = 10$ rad/s and $Q = 20$. Calculate the bandwidth of the circuit and also determine half power frequencies. [10M]

UNIT-V

10. Find the current in the 2Ω resistor as shown in the circuit below using both superposition theorem and Thevenin's theorem and compare the results in both the cases. [10M]

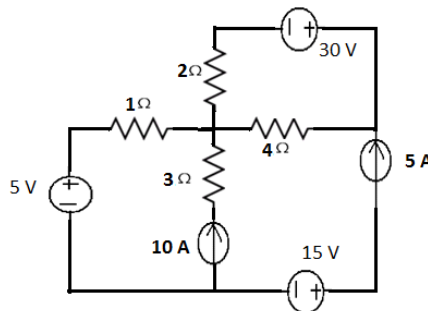

(OR)

11. In the circuit below, determine the current in 5Ω using both Thevenin's theorem and Norton's theorem and compare the results. [10M]

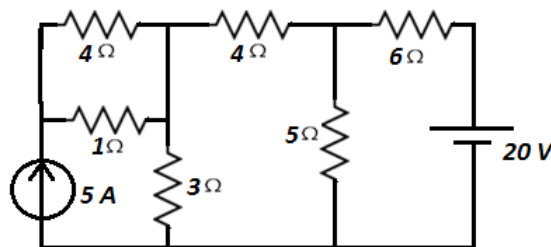

3 of 3



I B. Tech II Semester Regular Examinations, June/July-2024

NETWORK ANALYSIS

(Electronics and Communication Engineering)

Time: 3 hours

Max. Marks: 70

Note: 1. Question paper consists of two parts (**Part-A** and **Part-B**)

2. All the questions in **Part-A** is Compulsory

3. Answer **ONE** Question from each Unit in **Part-B**

PART – A (20 Marks)

1. a) Write the equations of energy stored by an inductor and capacitor [2M]
- b) State Maximum Power Transfer theorem. [2M]
- c) What is the time constant of a circuit having $R = 5 \Omega$, $L = 0.2H$. [2M]
- d) What is the behavior of inductor and capacitor at $t = \infty$ for DC excitation? [2M]
- e) What is the relation between real power , reactive power and apparent power [2M]
- f) What is 'j' operator? [2M]
- g) A series RLC circuit has the following parameters: $R = 2\Omega$, $L = 38 \mu H$ and $C = 44 \mu F$. Calculate the resonant frequency. [2M]
- h) Define mutual inductance. [2M]
- i) Draw the symmetrical Twin-T network. [2M]
- j) What are the different types of connection in two port network? [2M]

PART – B (50 MARKS)**UNIT-I**

2. a) For the circuit shown, find the power supplied 10 V source using mesh analysis. [5M]

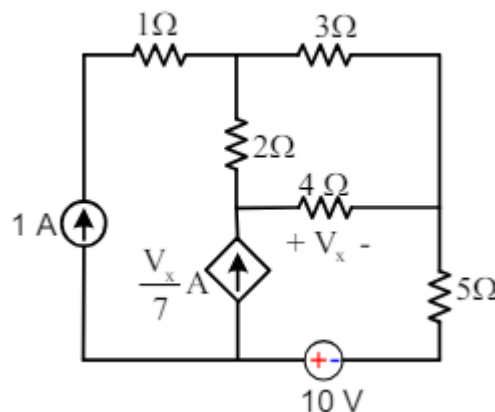

- b) Find the value of R_L for the network shown in Fig that results in maximum power transfer. Also find the value of maximum power. [5M]

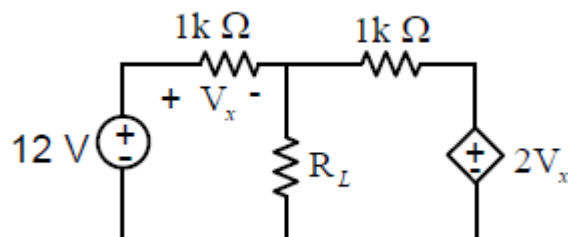

(OR)

- 3 a) In the circuit shown in Fig. determine all branch currents and the voltage across the $5\ \Omega$ resistor by node analysis. [5M]

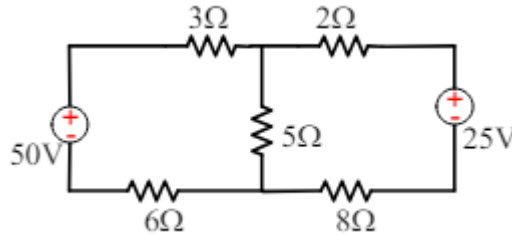

- b) Find the Thevenin and Norton equivalent for the circuit shown in Fig. with respect terminals a-b. [5M]

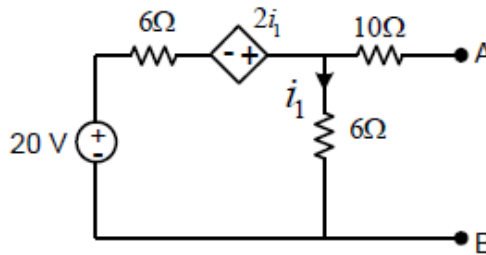

UNIT-II

4. a) A capacitor in an RC circuit with $R = 25\ \Omega$ and $C = 50\ \mu\text{F}$ is being charged with initial zero voltage. What is the time taken for the capacitor voltage to reach 40 % of its steady state value? [5M]

- b) Find $L\left(e^{-3t} \int_0^t t \sin^2 t\ dt\right)$ [5M]

(OR)

5. a) In an RC circuit, having a time constant of 2.5 ms, the capacitor discharges with initial voltage of 80 V. (a) Find the time at which the capacitor voltage reaches 55 V, 30 V and 10 V (b) Calculate the capacitor voltage at time 1.2 ms, 3 ms and 8 ms. [5M]

- b) [5M]

Find $L\left(e^{4t} \left(\int_0^t \frac{\sin 3t \cos 2t}{t} dt\right)\right)$

UNIT-III

6. a) In the arrangement shown in the figure. Calculate the impedance between AB and the phase angle between voltage and current. Also calculate the total power consumed, if the applied voltage between AB is $200\angle 30^\circ$ [5M]

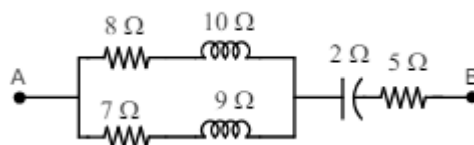

- b) A resistance R in series with a capacitor C is connected to 50 Hz, 240 V supply. Find the value of C so that R absorbs 300 W at 100 V. Find also maximum charge and maximum energy stored in C . [5M]

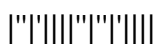

(OR)

7. a) A resistance of 7Ω is connected in series with a pure inductance of 31.8 mH and the circuit is connected to a 100 V 50 Hz sinusoidal supply. Calculate i) circuit current ii) Phase angle iii) Power factor iv) Power [5M]

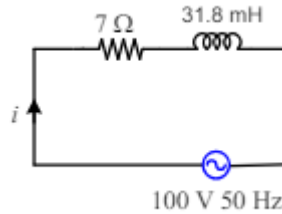

- b) When 220 V AC supply is applied across AB terminals for the circuit shown in Fig the power input is 3.25 kW and the current is 20 A . Find the current through Z_3 [5M]

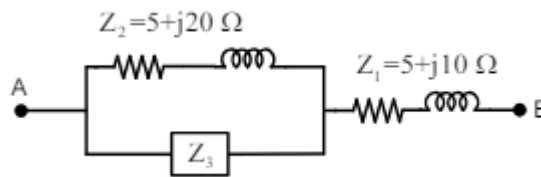

UNIT-IV

8. a) For the circuit shown in Figure Find (a) The resonant and half power frequencies (b) Calculate the quality factor and bandwidth (c) Determine the amplitude of the current at $\omega_0, \omega_1, \omega_2$ [5M]

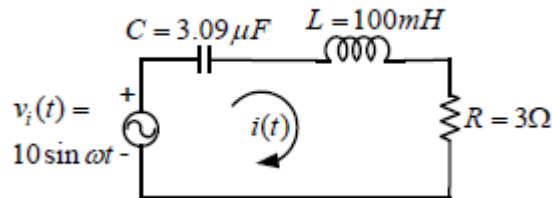

- b) Calculate the total inductance. [5M]

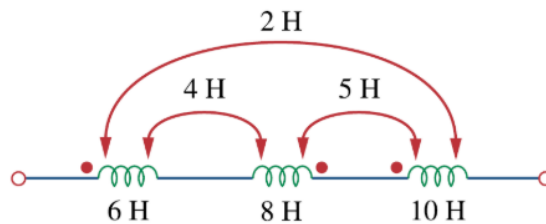

(OR)

9. a) For the circuit as shown in Figure find the resonant frequency and the corresponding current in each branch. [5M]

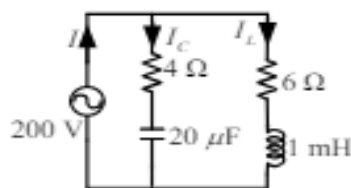

b) Calculate the total inductance.

[5M]

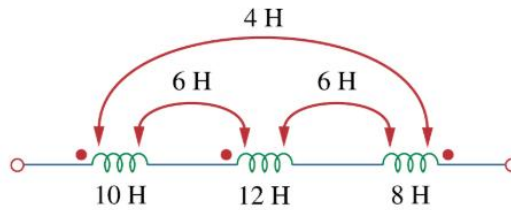

UNIT-V

10. a) Find the two-port parameters h_{12} and y_{12} for the network shown.

[5M]

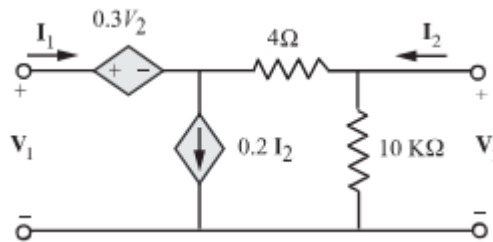

b) Select the values of R_A, R_B & R_C in the circuit shown so that $A = 1, B = 34 \Omega, C = 20 \text{ mS}$ and $D = 1.4$

[5M]

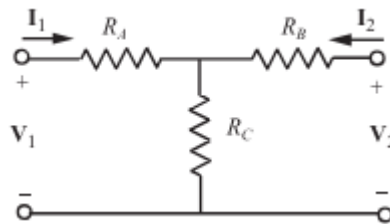

(OR)

11. a) Find the y parameters for the network shown.

[5M]

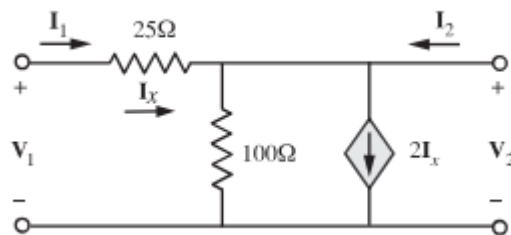

b) Find the s- domain expression for the h parameters of the circuit shown.

[5M]

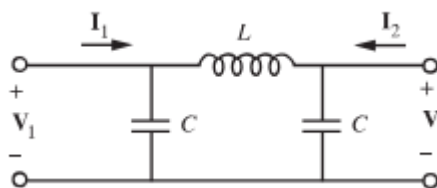



I B. Tech II Semester Regular Examinations, June/July-2024
NETWORK ANALYSIS

(Electronics and Communication Engineering)

Time: 3 hours

Max. Marks: 70

Note: 1. Question paper consists of two parts (Part-A and Part-B)
2. All the questions in Part-A is Compulsory
3. Answer ONE Question from each Unit in Part-B

PART - A (20 Marks)

1. a) State Kirchhoff's current law? [2M]
- b) Define loop and mesh. [2M]
- c) A series R-L circuit having $R=5\Omega$ and $L=0.1H$ is suddenly connected to a DC voltage of 10 Volts at $t=0$. What is the value of current at $t =$ time constant? [2M]
- d) What is free and forced response? [2M]
- e) Define phase difference. [2M]
- f) Determine the power factor of an RLC series circuit with $R=5\Omega$, $X_L=8\Omega$ and $X_C=12\Omega$. [2M]
- g) A Series RLC circuit has $R = 50\Omega$; $L = 100\mu H$; and $C = 300pF$; $V=20V$. What is the current at resonance? [2M]
- h) Define coefficient of coupling. [2M]
- i) What are the conditions for reciprocity for Z and Y parameters? [2M]
- j) Draw the symmetrical lattice network. [2M]

PART - B (50 MARKS)

UNIT-I

2. a) In the network shown, find the node voltages using nodal analysis. [5M]

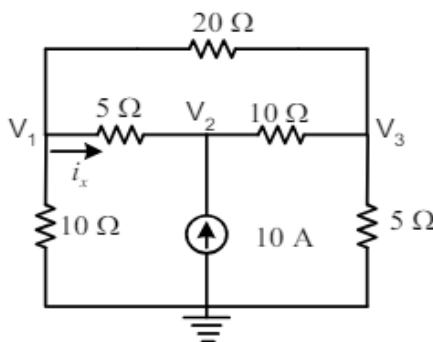

- b) Determine the Thevenin's equivalent of the circuit shown in Figure. [5M]

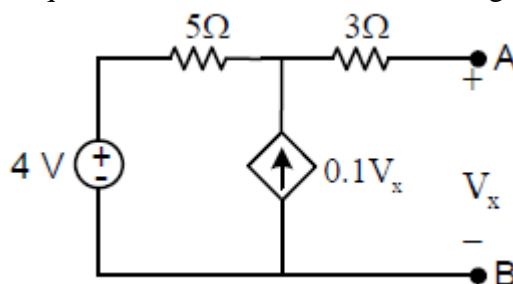

(OR)

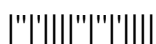

- 3 a) In the circuit shown in Fig determine the node voltages. [5M]

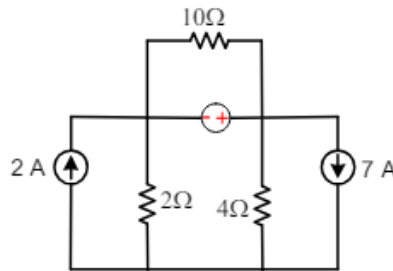

- b) Determine the current through the load resistance using Norton's theorem for the circuit shown in Figure. [5M]

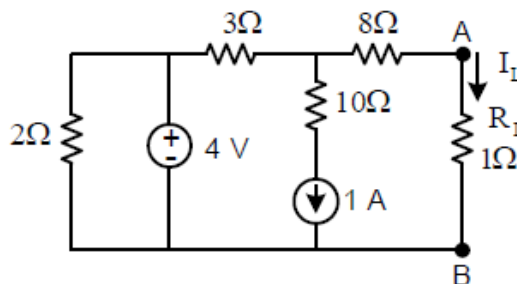

UNIT-II

4. a) The switch in circuit shown was in position 1 for a long time. It is moved from position 1 to position 2 at time $t = 0$. Sketch the wave form of $v_C(t)$ for $t > 0$. [5M]

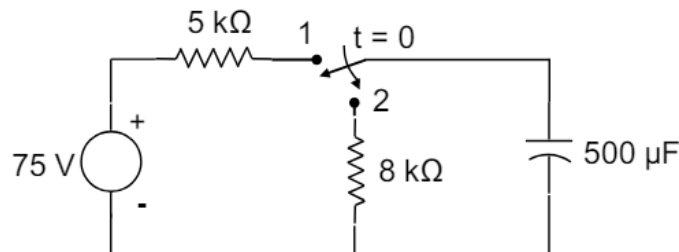

- b) Find the Laplace Transform of the square wave given. [5M]

$$f(t) = \begin{cases} E & \text{for } 0 < t < a/2 \\ -E & \text{for } a/2 < t < a \end{cases} \quad \text{and} \quad f(t+a) = f(t)$$

(OR)

5. a) A series RC circuit has a constant voltage of E , applied at time $t = 0$ as shown in Fig. below. [5M]
The capacitor has no initial charge. Find the equations for i , v_R and v_C . Sketch the wave shapes.

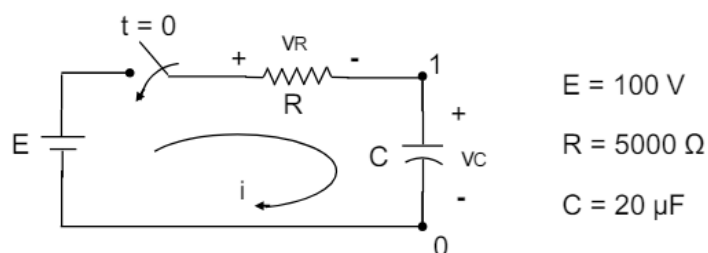

$$E = 100 \text{ V}$$

$$R = 5000 \Omega$$

$$C = 20 \mu\text{F}$$

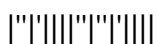

- b) Find the Laplace transform of the function [5M]

$$f(t) = \begin{cases} t & 0 < t < b \\ 2b - t & b < t < 2b \end{cases}$$

UNIT-III

6. a) A coil having a resistance of 20Ω and inductance of 0.0382 H , is connected in parallel with a circuit consisting of a $150 \mu\text{F}$ capacitor in series with 10Ω resistor. The arrangement is connected to a 230 V , 50 Hz supply. Determine current in each branch. Also find total supply current. [5M]

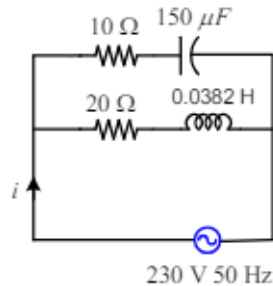

- b) An alternating voltage of $(80 + j60) \text{ V}$ is applied to a circuit and the current flowing through it is $(-4 + j10) \text{ A}$. Find the i) impedance of the circuit ii) phase angle iii) pf of the circuit iv) power consumed by the circuit. [5M]

(OR)

7. a) An alternating voltage of $(160 + j120) \text{ V}$ is applied to a circuit and the current is given by $(6 + j8) \text{ A}$. Find the values of circuit elements by assuming $f = 50 \text{ Hz}$. Calculate the power factor of the circuit and power consumed by the circuit. [5M]

- b) For the circuit shown in Fig. find current in all branches. Draw vector diagram [5M]

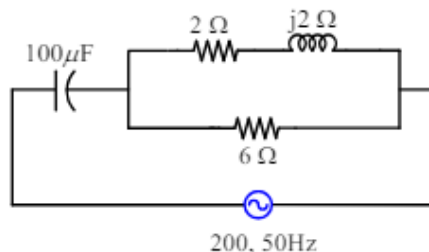

UNIT-IV

8. a) For the circuit shown in Figure find the resonant frequency, quality factor and bandwidth for the circuit. Determine the change in Q and the bandwidth if R is changed from $R = 2 \Omega$ to $R = 0.4 \Omega$ [5M]

- b) Two coils connected in series-aiding fashion have a total inductance of 250 mH . When connected in a series-opposing configuration, the coils have a total inductance of 150 mH . If the inductance of one coil (L_1) is three times the other, find L_1 , L_2 , and M. [5M]

(OR)

9. a) Find the value of L for which the circuit as shown in Fig. is resonance at 1000 Hz . [5M]

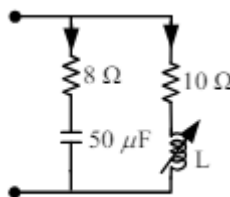

- b) Calculate the mesh currents in this circuit. [5M]

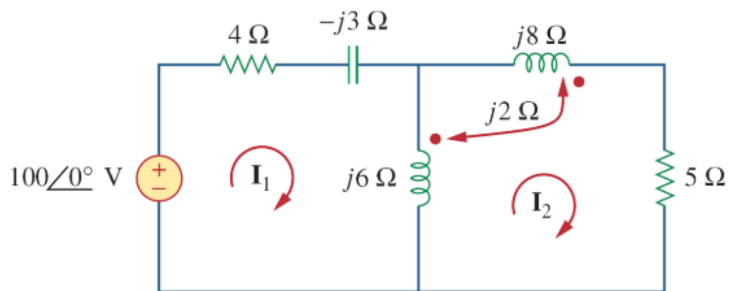

UNIT-V

10. a) Determine the admittance parameters of the T network shown. [5M]

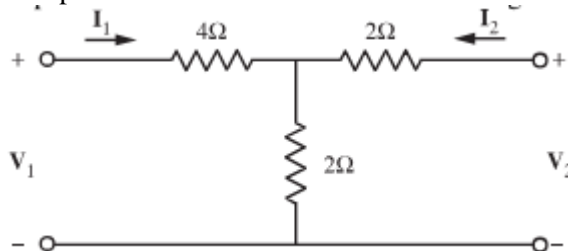

- b) For the network shown, show that AD- BC = 1/ [5M]

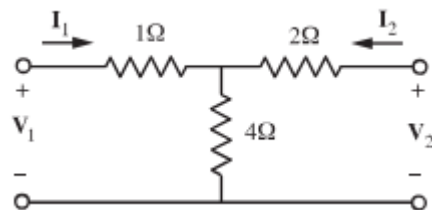

(OR)

11. a) Find the y parameters for the two-port network shown. [5M]

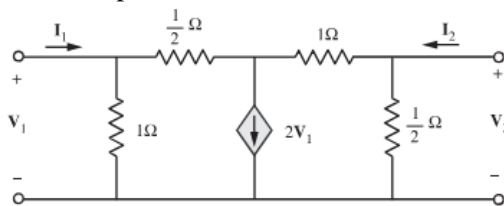

- b) Obtain the h-parameters for the network shown. [5M]

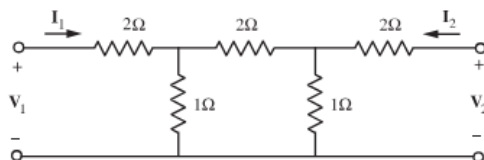



I B. Tech II Semester Regular Examinations, June/July-2024

NETWORK ANALYSIS

(Electronics and Communication Engineering)

Time: 3 hours

Max. Marks: 70

Note: 1. Question paper consists of two parts (**Part-A** and **Part-B**)

2. All the questions in **Part-A** is Compulsory

3. Answer **ONE** Question from each Unit in **Part-B**

PART – A (20 Marks)

1. a) What is meant by source transformation? [2M]
- b) State Compensation Substitution theorem. [2M]
- c) Why transients occurs in electric circuits. [2M]
- d) Write down few applications of RL, RC and RLC circuits. [2M]
- e) Draw the phasor diagram of pure capacitor. [2M]
- f) Define impedance and admittance. [2M]
- g) Define Band width and selectivity. [2M]
- h) Express series aiding series opposing of two mutual coils. [2M]
- i) Write down the Expressions for z parameters in terms of y parameters. [2M]
- j) Define propagation constant. [2M]

PART – B (50 MARKS)**UNIT-I**

2. a) Find V and I using mesh analysis. [5M]

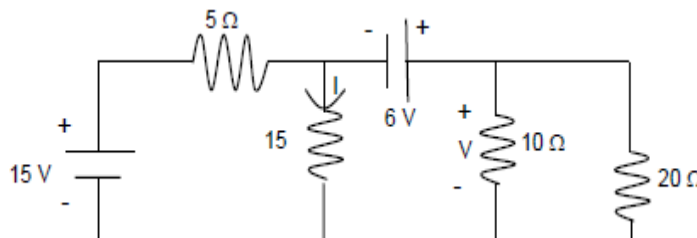

- b) Find the value of Z_L in the circuit shown using maximum power transfer theorem and hence the maximum power. [5M]

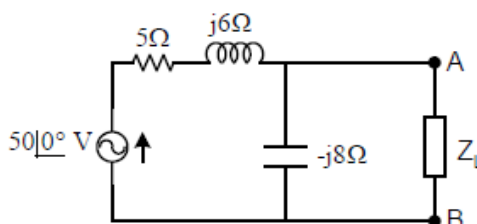

(OR)

3. a) In the circuit shown, determine the mesh currents i_1 , i_2 , i_3 . [5M]

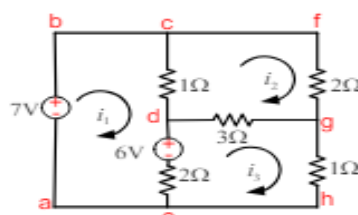

- b) Find the current through 6 Ω resistor using Norton's theorem for the circuit shown [5M]

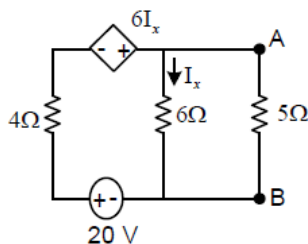

UNIT-II

4. a) Consider the circuit shown. The switch was in open position for a long time. It is operated as shown. Compute and plot the capacitor voltage for $t > 0$. Also find the time at which the capacitor voltage is 50 V. [5M]

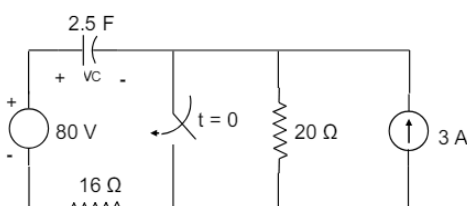

- b) [5M]

$$f(t) = \begin{cases} \sin t & \text{in } 0 < t < \pi \\ 0 & \text{in } \pi < t < 2\pi \end{cases} \text{ and } f(t+2\pi) = f(t).$$

Find the Laplace transform of

(OR)

5. a) Consider the circuit shown below. The switch was in position S+ for a long time. It is operated as shown. Compute and plot the capacitor voltage for $t > 0$. Also find the time at which the capacitor voltage becomes zero. [5M]

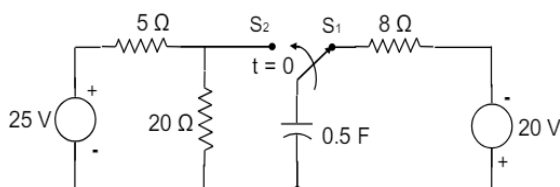

- b) Find the Laplace transform of the Half-wave rectifier function [5M]

$$f(t) = \begin{cases} \sin wt, & 0 < t < \frac{\pi}{w} \\ 0, & \frac{\pi}{w} < t < \frac{2\pi}{w} \end{cases}$$



UNIT-III

6. a) Two impedances $Z_1 = 150 - j157 \Omega$ and $Z_2 = 100 - j110 \Omega$ Find (i) Branch Currents [5M]
(ii) Total current (iii) Total power (iv) Draw vector Diagram.

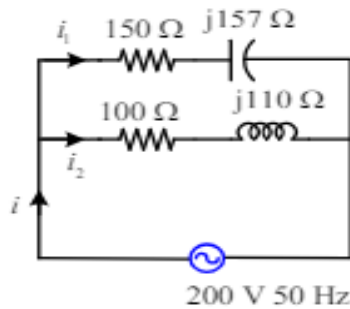

- b) Compute total Z and Y for the circuit shown below. [5M]

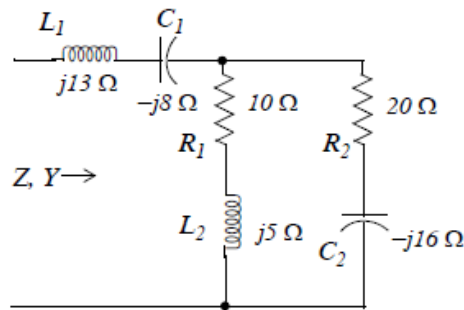

(OR)

7. a) Two parallel circuits comprising of (i) a coil of resistance of 20Ω and inductance of 0.07 H and (ii) a resistance of 50Ω in series with a condenser of capacitance $60 \mu\text{F}$ are connected across 230 V , 50 Hz . Calculate the main current and power factor of the arrangement. [5M]

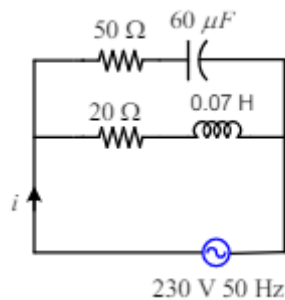

- b) Compute total Z & Y for the circuit shown below. [5M]

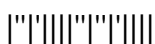
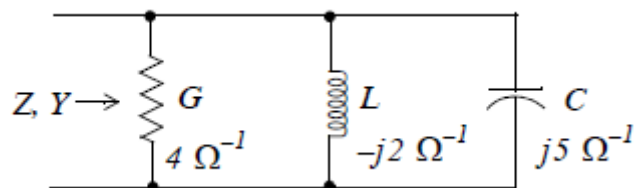

UNIT-IV

8. a) Differentiate between mutual inductance and self inductance. [5M]
 b) Determine the coupling coefficient and calculate the energy stored in the coupled inductors at time $t = 1s$. [5M]

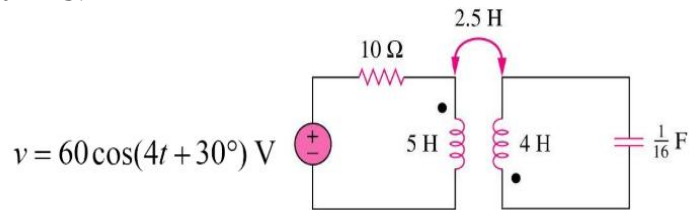

(OR)

9. a) Find the value of C for which the circuit as shown in Figure is resonance at 750 Hz. [5M]

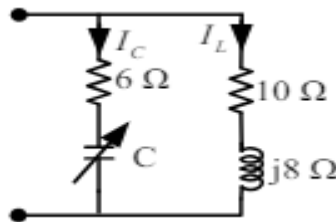

- b) Given, $L_1=40mH$, $L_2=5mH$, and coupling coefficient $k=0.6$. Find $i_1(t)$ and $v_2 t$, given that $v_1(t) = 10\cos\omega t$ and $i_2(t) = 2\sin\omega t$, $\omega = 2000 \text{ rad/s}$. [5M]

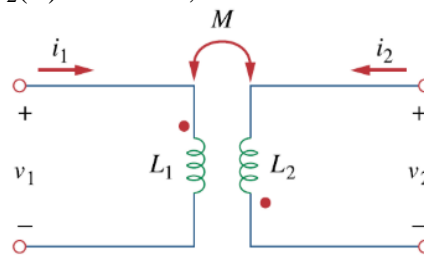

UNIT-V

10. a) Obtain the Z parameters of the two-port. [5M]

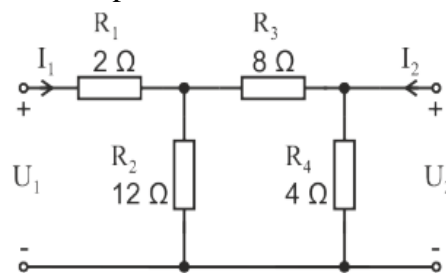

- b) Explain about cascading of two-port networks with an example. [5M]

(OR)

11. a) Obtain the hybrid (H) parameters of the two-port. [5M]

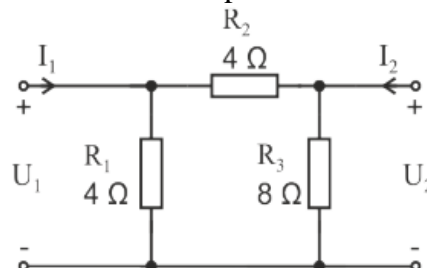

- b) Explain in detail about interconnection of two port networks. [5M]

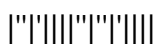

I B. Tech II Semester Regular Examinations, June/July-2024

NETWORK ANALYSIS

(Electronics and Communication Engineering)

Time: 3 hours

Max. Marks: 70

Note: 1. Question paper consists of two parts (**Part-A** and **Part-B**)

2. All the questions in **Part-A** is Compulsory

3. Answer **ONE** Question from each Unit in **Part-B**

PART – A (20 Marks)

1. a) State Reciprocity theorem. [2M]
- b) Differentiate active and passive elements. [2M]
- c) Write an expression for $i(t)$ in a series R-L Circuit when a DC Voltage of 10V is suddenly applied at $t = 0$? [2M]
- d) Define transient analysis. [2M]
- e) Define phase of an alternating quantity. [2M]
- f) Draw the phasor diagram for pure inductor and resistor. [2M]
- g) What are half power frequencies? [2M]
- h) State the applications of dot rule. [2M]
- i) Define Iterative impedance. [2M]
- j) What is Lattice network? [2M]

PART – B (50 MARKS)**UNIT-I**

2. a) Determine the current through $2\ \Omega$ resistor in the circuit shown. [5M]

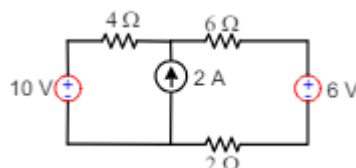

- b) Find the value of Z_L for which maximum power is transfer occurs in the circuit shown. [5M]

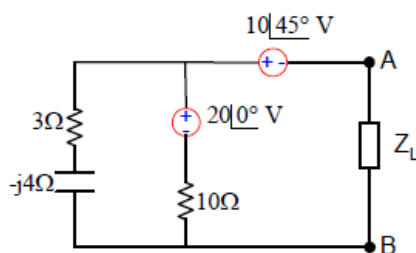

(OR)

3. a) Find the voltage across $20\ \Omega$ resistor in the network shown by mesh analysis. [5M]

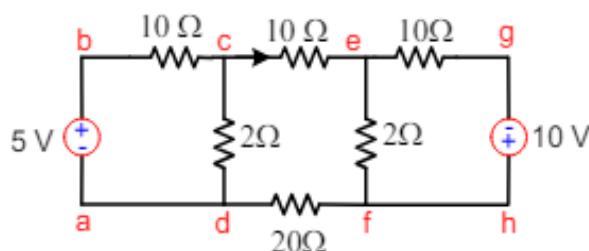

- b) Find the Thevenin equivalent for the circuit shown in Fig. with respect terminals a-b. [5M]

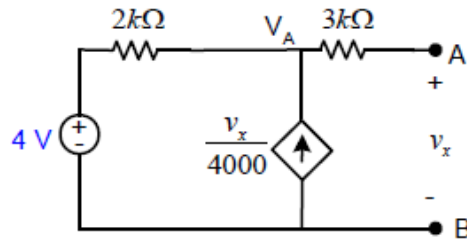

UNIT-II

4. a) In a RL circuit with time constant of 1.25 s, inductor current increases from the initial value of zero to the final value of 1.2 A. (a) Calculate the inductor current at time 0.4 s, 0.8 s and 2 s. (b) Find the time at which the inductor current reaches 0.3 A, 0.6 A and 0.9 A. [5M]
- b) Find the Laplace transform of the function. [5M]

$$f(t) = \begin{cases} t, & 0 < t < \frac{\pi}{2} \\ \pi - t, & \frac{\pi}{2} < t < \pi \end{cases} \quad f(\pi + t) = f(t)$$

(OR)

5. a) In an RL circuit having time constant 400 ms the inductor current decays and its value at 500 ms is 0.8 A. Find the equation of $i_L(t)$ for $t > 0$. [5M]
- b) Find the Laplace transform of the periodic function. [5M]

$$f(t) = \begin{cases} t, & \text{for } 0 < t < 1 \\ 2-t, & \text{for } 1 < t < 2 \end{cases} \quad \text{and } f(t+2) = f(t)$$

UNIT-III

6. a) A certain circuit takes a current of $(-5+j10)$ amperes when applied voltage is $(50+j200)$ volts. If the frequency of the supply is 50 Hz. i) Find the circuit elements ii) apparent power iii) reactive power iv) power factor. [5M]
- b) For the circuit below, find the current $i(t)$ [5M]

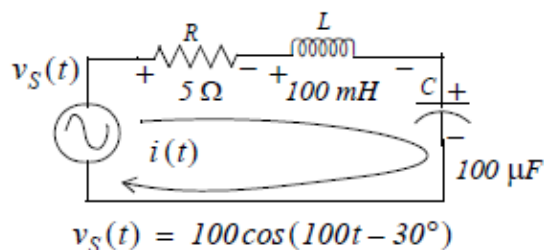

(OR)

7. a) A series circuit of resistance of 10Ω , an inductance of 13 mH and a capacitance of 150 μF connected in series. A supply of 100 V at 50 Hz is given to the circuit. Find the impedance, current pf and power consumed in the circuit. [5M]

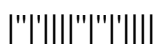

- b) For the circuit shown below, find $i_c(t)$ [5M]

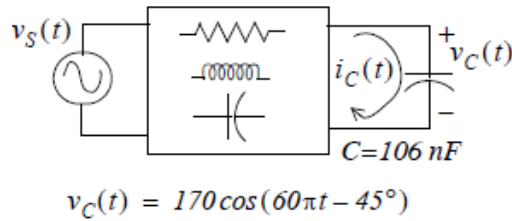

UNIT-IV

8. a) For the circuit shown in Figure the maximum amplitude of current is 10A, circuit quality factor Q is 100 and $L=0.1H$. If the applied voltage is 100 V find the value of capacitance. [5M]
 b) Calculate the phase currents I_1 & I_2 for the given circuit [5M]

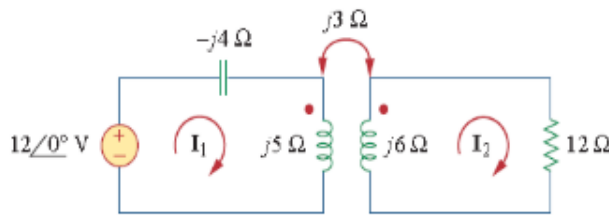

(OR)

9. a) The Q of a series circuit network is 10. The maximum amplitude of current at resonance is 1 A when applied voltage is 10 V. If $L=0.1H$ find the value of capacitance. [5M]
 b) Calculate the mesh currents for the given circuit [5M]

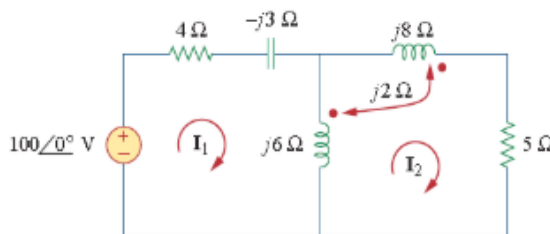

UNIT-V

10. a) Derive the expression for image impedance for asymmetrical T and π network. [5M]
 b) Derive the expression for types of interconnection of two port networks [5M]

(OR)

11. a) Determine the impedance parameters from the circuit in Fig [5M]

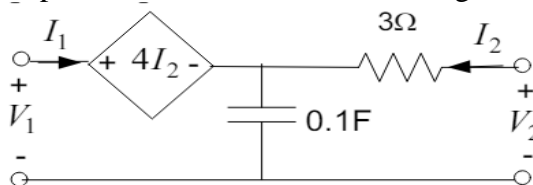

- b) Find the h-parameters for the network shown in figure below. [5M]

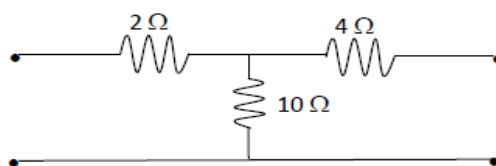

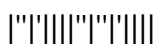

I B. Tech II Semester Supplementary Examinations, June/July- 2024

ELECTRICAL CIRCUIT ANALYSIS –I

(Electrical and Electronics Engineering)

Time: 3 hours

Max. Marks: 70

Answer any FIVE Questions ONE Question from Each Unit

All Questions Carry Equal Marks

UNIT-I

1. a) Find the voltage across the $3\ \Omega$ resistor by nodal analysis. [7M]

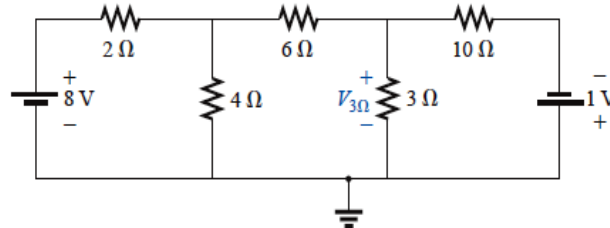

- b) Explain Y to Δ transformation technique? [7M]

(OR)

2. a) Determine v_3 for the circuit shown below using mesh analysis? [7M]

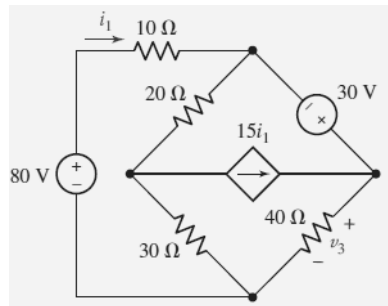

- b) Explain source transformation technique with an example? [7M]

UNIT-II

3. a) Obtain an expression for Co-efficient of coupling. [7M]

- b) A mild steel ring has a radius of 50 mm and a cross sectional area of $400\ \text{mm}^2$. A current of 0.5 A flows in a coil wound uniformly around the ring and the flux produced is 0.1 mWb. If the relative permeability at this value of current is 200 find (i) the reluctance of the mild steel (ii) the number of turns on the coil. [7M]

(OR)

4. a) Explain the concept of self and mutual inductance? [7M]

- b) A mild steel closed magnetic circuit has a mean length of 75 mm and a cross-sectional area of $320.2\ \text{mm}^2$. A current of 0.4A flows in a coil wound uniformly around the circuit and the flux produced is $200\ \mu\text{Wb}$. If the relative permeability of the steel at this value of current is 400 find (i) the reluctance of the material and (ii) the number of turns of the coil. [7M]

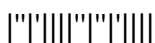

UNIT-III

5. a) Determine the power factor of the circuit seen by the source for the network [7M] shown below. Also calculate the average power delivered by the source.

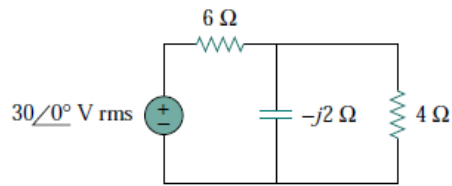

- b) Calculate the RMS value of the current wave form shown below? [7M]

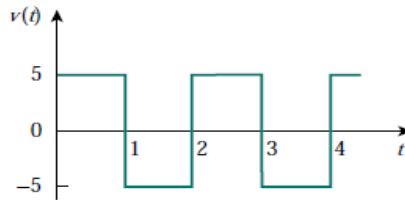

(OR)

6. a) Find the average and RMS values of the voltage waveform shown? [7M]

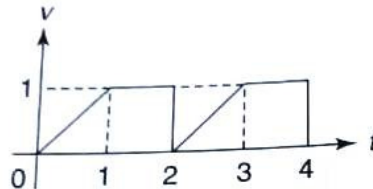

- b) A load of 22 kW operates at 0.8 lagging power factor when connected to a 420 V, single phase 50 Hz source. Find (i) Current in the load (ii) power factor angle (iii) impedance (iv) resistance of the load (v) reactance of the load (vi) Voltage and current equations. [7M]

UNIT-IV

7. a) A coil of negligible resistance and inductance 100mH is connected in series with a capacitance of 2 μF and a resistance of 10Ω across a 50V, variable frequency supply. Determine (a) the resonant frequency, (b) the current at resonance, (c) the voltages across the coil and the capacitor at resonance, and (d) the Q-factor of the circuit. [7M]
- b) A capacitor C is in series with a 75 Ω resistor and a 12 H coil across a 220 V, 60 Hz supply. Determine the value of 'C' that resonates the circuit. [7M]

(OR)

8. a) A series R–L–C circuit has a supply input of 5 volts. Given that inductance, L = 5 mH, resistance, R = 75 Ω and capacitance, C = 0.2 μF, determine (i) the resonant frequency, (ii) the value of voltage across the capacitor at the resonant frequency, (iii) the frequency at which the p.d. across the capacitance is a maximum, and (iv) the value of the maximum voltage across the capacitor [7M]
- b) Show that the locus of current of a series circuit consisting of resistance and inductance with resistance varied and inductance reactance fixed, when supplied by a constant AC Voltage source, lies on circular path. [7M]

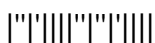

UNIT-V

9. a) State and explain Norton's theorem with an example? [7M]
b) For the circuit shown below in calculate i_x and the power dissipated by the $10\text{-}\Omega$ resistor using superposition. [7M]

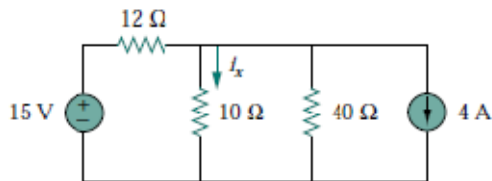
**(OR)**

10. a) State and explain reciprocity theorem with an example? [7M]
b) Find the value of R_L for the maximum power to be transferred to it and find maximum power that is transferred [7M]

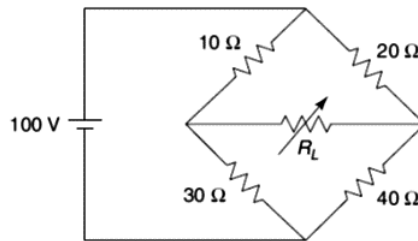



I B. Tech II Semester Supplementary Examinations, June/July-2024**DATA STRUCTURES**

(Common to CSE, IT, CSE-AI&ML, CSE-AI, CSE-DS, CSE-AI&DS, AI&DS)

Time: 3 hours

Max. Marks: 70

*Answer any FIVE Questions ONE Question from Each Unit**All Questions Carry Equal Marks***UNIT-I**

1. a) Compare the working of linear and binary search with the help of a case study. [7M]
 b) Develop the logic for Exchange sort and trace it using example elements. [7M]

(OR)

2. a) Discuss the working of Quick Sort for the following input: (i) Sorted elements (like 2,6,9...) (ii) same elements (like 3,3,3,3,3...) [7M]
 b) Develop the program to perform Merge sort on a given array of elements. [7M]

UNIT-II

3. a) Show the implementation of insertion and deletion operations on double linked list. [7M]
 b) Develop a program to create two single circular linked lists and concatenate them. [7M]

(OR)

4. a) Develop an optimised linked list to create a list and traverse it backwards. [7M]
 b) Demonstrate the sparse matrix representation using a linked list. [7M]

UNIT-III

5. a) Develop a program to create a Queue using arrays and discuss its limitations. [7M]
 b) Demonstrate the logic for reversing a list using suitable diagrams. [7M]

(OR)

6. a) Describe the linked list representation stacks and use it for generating post fix notation of an arithmetic expression. [7M]
 b) Develop a program to create a stack and perform push and pop operations using dynamic memory management. [7M]

UNIT-IV

7. a) Develop a program to perform Heap sort on given user input. [7M]
 b) Demonstrate the deletion of an element from the existing AVL tree using a case study. [7M]

(OR)

8. a) Demonstrate the search operation on a binary search tree with the help of an example. [7M]
 b) Develop a program to create, insert elements into and delete from the binary tree using a linked list. [7M]

UNIT-V

9. a) Develop a program to implement BFS on the given input graph. [7M]
 b) Illustrate the working principle of Dijkstra's algorithm to find out the shortest path from a node in the graph. [7M]

(OR)

- 10 a) Demonstrate transitive closure with an example and discuss the advantages of it. [7M]
 b) Develop a program to compute the minimum spanning tree of a given input graph using the Kruskals' algorithm. [7M]



I B. Tech II Semester Supplementary Examinations, June/July-2024**DIGITAL LOGIC DESIGN**

(Common to CSE, IT)

Time: 3 hours

Max. Marks: 75

*Answer any FIVE Questions ONE Question from Each Unit**All Questions Carry Equal Marks***UNIT-I**

1. a) Express the following numbers in decimal: $(10110.0101)_2$, $(16.5)_{16}$, $(26.24)_8$. [8M]
 b) What are 2's complement and 1's complement of a numbers? Perform the subtraction in binary using 1's and 2's complement methods. [7M]
 i. $(97)_{10} - (255)_{10}$ ii. $(1111101)_2 - (100111110)_2$

(OR)

2. a) Write the procedure to convert binary to gray code and gray code to binary? [8M]
 Convert $(10110)_2$ to Gray code and $(110101)_G$ to binary number.
 b) Distinguish between weighted and non-weighted codes with example. Write the code words for 0-9 using BCD and Excess-3 code? [7M]

UNIT-II

3. a) What are the different derived gates? Implement Exclusive OR function involving three variables using only NOR function. [8M]
 b) Define pair, quad and octet in K-Maps and give examples. Reduce the following expression using k-map $f = \sum m(1, 4, 5, 11, 12, 14) . d(6, 7, 15)$ [7M]

(OR)

4. a) Distinguish between canonical and standard forms by giving an example. Write down the procedure to convert a AND-OR gate network to all NAND gate network and illustrate with an example. [8M]
 b) Reduce the following expression using Boolean algebra rules [7M]
 i. $((AB + ABC)' + A(B + AB))'$
 ii. $T(x, y, z) = (x + y) \{ [x' (y' + z')] \} + x' y' + x' z'$

UNIT-III

5. a) Draw the PLA diagram for the four Boolean functions listed below. [8M]
 $A(x, y, z) = \sum m(0, 1, 2, 4, 6)$ $B(x, y, z) = \sum m(0, 2, 6, 7)$
 $C(x, y, z) = \sum m(3, 6)$ $D(x, y, z) = \sum m(1, 3, 5, 7)$
 b) What is a parallel adder? Write a HDL code for four bit parallel adder/subtractor. [7M]

(OR)

6. a) Construct 3 to 8 line decoder with logic gates and enable input. Also write the HDL code for the same. [8M]
 b) Realize the function $f(A,B,C,D) = \sum (1,2,5,8,10,14) + d(6,7,15)$ using [7M]
 i) 8:1 MUX ii) 4:1 MUX

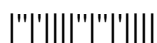

UNIT-IV

7. a) What is the race around condition? Design a flip flop which overcomes this drawback and explain with neat diagram. [8M]

b) Analyze latch with NOR gates, derive transition, flow and state tables. [7M]

(OR)

8. a) What is a flip-flop? Write down the characteristic equation of S-R flip flop. Convert an SR Flip-Flop into JK Flip-Flop. [8M]

b) Explain the operation of clocked D-flip-flop with NAND gates using truth table. Give its timing diagram. [7M]

UNIT-V

9. a) Define shift register? Draw the block diagram and timing diagram of a shift register that shows the serial transfer of information from register A to register B. [8M]

b) What are the various methods used for triggering flip-flops? Explain with examples. Also list out the applications of counter? [7M]

(OR)

10. a) Design a type-D counter that goes through states 0, 2, 4, 6, 0..... The undesired states must always go to a 0 on the next clock pulse. [8M]

b) Draw and explain 4-bit universal shift register. [7M]

